

# **NOIDA METRO RAIL CORPORATION (NMRC) LIMITED**

**REQUEST FOR PROPOSAL (RFP)**

**Open e-Tender No. NMRC/DCOS/RS/360R2/440/2026**

**Supply of Pantograph Carbon Strips for Rolling Stock Department**

**March 2026**

**Issued by:**

**Noida Metro Rail Corporation (NMRC) Limited Block-  
III, 3<sup>rd</sup> Floor,  
Ganga Shopping Complex, Sector-29, Noida -201301,  
District Gautam Buddha Nagar, Uttar Pradesh, India**

## **Disclaimer**

This Request for Proposal (RFP) Document (or “Tender” or “Bid”) for “**Supply of Pantograph Carbon Strips for Rolling Stock Department**” contains brief information about the scope of work and selection process for the Bidder (‘the Contractor’ or “the Bidder” or “the Applicant”). The purpose of the Document is to provide the Bidders with information to assist the formulation of their Bidding Documents.

While all efforts have been made to ensure the accuracy of information contained in this RFP Document, this Document does not purport to contain all the information required by the Bidders. The Bidders should conduct their own independent assessment, investigations and analysis and should check the reliability, accuracy and completeness of the information at their end and obtain independent advice from relevant sources as required before submission of their Bid/s. Noida Metro Rail Corporation Ltd. (“NMRC” or “the Corporation”) or any of its employees or advisors shall incur no liability under any law, statute, rules or regulations as to the accuracy or completeness of the RFP Document.

NMRC reserves the right to change any or all conditions/information set in this RFP Document by way of revision, deletion, updating or annulment through issuance of appropriate addendum as NMRC may deem fit without assigning any reason thereof.

NMRC reserves the right to accept or reject any or all Bids without giving any reasons thereof. NMRC will not entertain or be liable for any claim for costs and expenses in relation to the preparation of the Bid/s to be submitted in terms of this RFP Document.

## Glossary

- a) **“Addendum / Amendment”** means any written amendment / addendum /corrigendum to this RFP, from time to time issued by NMRC to the prospective bidders;
- b) **“Agreement”** means the Contract Agreement to be executed between NMRC and the selected bidder.
- c) **“Applicable Laws”** means all laws, brought into force and effect by Govt. of India, State Governments, local bodies and statutory agencies and rules / regulations / notifications issued by them from time to time. It also include judgments, decrees, injunctions, writs and orders of any court or judicial authority as may be in force and effected from time to time.
- d) **“Bidder”** or **“Bidder”** means Sole proprietorship, registered partnership firm, public limited company, private limited company which is submitting its bid pursuant to RFP Documents
- e) **“Bid Due Date”** means Bid Submission end date and time given in the tender
- f) **“Earnest Money Deposit (EMD)”** means the refundable amount to be submitted by the Bidder along with RFP documents to NMRC
- g) **“Interest Free Security Deposit/ Performance Security”** means interest free amount to be deposited by the Contractor with NMRC as per terms and conditions of Contract Agreement as a security against the performance of the Contract agreement.
- h) **“NMRC”** means Noida Metro Rail Corporation Limited ( or “Corporation” )
- i) **“Party”** means Contractor or Corporation (together they are called **“Parties”**)
- j) **“Performance Bank Guarantee/ Security Deposit”** means interest free amount to be deposited by the Contractor with NMRC as per terms and conditions of Purchase Order as a security against the performance of the Contract agreement
- k) **“Permits”** shall mean and include all applicable statutory, environmental or regulatory Contracts, authorization, permits, consents, approvals, registrations and franchises from concerned authorities l) **“Re. or Rs. or INR”** means Indian Rupee
- m) **“Revenue Operations Date (ROD)”** means the date of operation of metro
- n) **“Selected Bidder”** means the bidder who has been selected by NMRC, pursuant to the bidding process for award of Contract.

The words and expressions beginning with capital letters and defined in this document shall, unless repugnant to the context, have the meaning ascribed thereto hereinabove.

## Data Sheet

1	Name of the Bid	Supply of Pantograph Carbon Strips for Rolling Stock Department
2	Approximate Cost of Work	INR 33,45,300/-(Inclusive of GST)
3	Time period of contract	24 weeks for Supply plus 12 Months warranty
4	Mode of Tender	Open e-Tender
5	Bid Processing Fee	Rs. 5,900/- (Rupees Five Thousand Nine Hundred Only) through RTGS/NEFT only payable in favour of Noida Metro Rail Corporation Limited
6	Ernest Money Deposit (EMD)	Rs. 67,000/- (Rupees Sixty Seven Thousand Only) through RTGS/NEFT only payable in favour of Noida Metro Rail Corporation Limited
7	System of Tendering	Single stage Two Packet/Bid System (Technical bid and Financial bid) to be submitted together on e-Tender portal.
8	Financial Bid to be submitted together with Technical Bid	Yes

Supply of Pantograph Carbon Strips for Rolling Stock Department

9	Name of the Corporation's official for addressing queries and clarifications	JGM/Stores Noida Metro Rail Corporation Limited, Block-III, 3rd Floor, Ganga Shopping Complex, Sector-29, Noida 201301 <b>Email: <a href="mailto:nmrc.afc@gmail.com">nmrc.afc@gmail.com</a></b>
10	Bid Validity Period	180 days
11	Bid Language	English
12	Bid Currency	INR
13	<b>Schedule of Bidding Process</b>	
	<b>Task</b>	<b>Key Dates</b>
	Uploading of Bid	25-03-2026
	Pre-bid Meeting	02-04-2026 at 11:00 Hrs at NMRC Head Office
	Last date of receipt of Pre-bid queries	02-04-2026 up to 1400 Hrs
	Last date of issuing amendment, if any	10-04-2026
	Last Date of Bid Submission	27-04-2026 [Time 15:00 hrs]
	Date of Technical Bid Opening	27-04-2026 [Time 15:30 hrs]
Place of Bid Opening	Noida Metro Rail Corporation, Block-III, 3rd Floor, Ganga Shopping Complex, Sector-29, Noida 201301	
14	JV/Consortium to be allowed	<b>No</b>
15	Account details	<b>For Bid Processing Fee &amp; EMD</b> State Bank of India (04077) – Sector 18, Noida Gautam Buddha Nagar, Uttar Pradesh 201301 IFSC Code: SBIN0004077 <b>A/c No. 37707840592</b> <b>Noida Metro Rail Corporation Ltd.</b>

**Content**

**Disclaimer** ..... 1

**Data Sheet**.....3

**1. Section 1: General Information** ..... 5

    Background ..... 5

    About Locations ..... 5

    Communication ..... 5

**2. Section 2: Terms of Reference** ..... 6

    Tenure ..... 6

    Scope of work ..... 6

    Pre-dispatch inspection at Seller premises.....6

    Obligation To contractor ..... 7

**3. Section 3: Instructions to Bidders** ..... 8

    General instructions ..... 8

    Preparation and submission of Bids ..... 10

    Earnest Money Deposit ..... 14

    Opening and Evaluation of Bids ..... 15

    Award of Contract ..... 16

**4. Section 4: Eligibility, Evaluation and Selection Process** ..... 18

    Eligibility Criteria ..... 18

    Information of the Technical and Financial Proposal ..... 19

    Purchase Order ..... 19

    Performance Bank Guarantee / Security Deposit ..... 19

    Contact during Proposal Evaluation ..... 20

    Financial Terms ..... 20

**5. Section 5: General Conditions of Contract (GCC)** ..... 22

**6. Section 6: Draft contract agreement** ..... 27

**7. Section 7: Forms** ..... 29

**Form 1: Letter of Proposal Submission** ..... 29

**Form 2: Firm Details** ..... 30

**Form 3: Work Experience** ..... 31

**Form 4: Capability Statement**.....32

**Form 5: Financial Capability Details** ..... 34

**Form 6: Memorandum** ..... 36

**Form 7: Undertaking**.....37

**Form 8: Power of Attorney**.....38

**Form 9: Saleable Form for Tender Document** ..... 40

**Form 10: Declaration of Refund of Earnest Money** ..... 41

**Form 11: Performa for Clarifications / Amendments on the RFP**.....42

**Form 12: Bid Offer/ BOQ (Format)**..... 43

**Form 13: Performa of performance security/Bank Guarantee by Bank** ..... 45

**Form 14: Bid Details** ..... 47

**Annexure-A**.....48

## 1. Section 1: General Information

### Background

- a. Noida and Greater Noida are being developed as the satellite towns to New Delhi and more and more people from Delhi and other areas are shifting to these towns in search of fresh air, greenery and better infrastructure. There is a need of providing an efficient, reliable and comfortable transportation system for the population intending to settle in these towns and also the public coming to these areas for education, service and business.
- b. Noida Metro Rail Corporation is a Special Purpose Vehicle (SPV) formed for planning and executing urban transport projects in Noida, Greater Noida regions. The Company desires to provide a world-class Public Transportation System with state of the art technology. As such, the overarching criterion for setting up of the Company is to help create an efficient, safe, reliable, economical and affordable public transport system
- c. An elevated metro line between Noida and Greater Noida is already in operation.
- d. NMRC invites open bid for granting the Contract **for Supply of Pantograph Carbon Strips for Rolling Stock Department.**
- e. If Successful, Bidder shall provide the services as described in **Section 2: Terms of Reference.**

### About Locations

The metro corridor is 29.7 km long and is known as Noida Greater Noida Metro Rail Corridor. It comprises 21 metro stations starting from Noida Sector 51 in Noida and ends up at Depot Station in Greater Noida. Pantograph Carbon Strips are to be supplied at Main Stores (DCOS) Building, Metro Depot at Greater Noida.

### Communication

All communications should be addressed to:

JGM/Stores

Noida Metro Rail Corporation Limited,

Block-III, 3rd Floor, Ganga Shopping Complex, Sector-29, Noida 201301

Email: [nmrc.afc@gmail.com](mailto:nmrc.afc@gmail.com)

## 2. Section 2: Terms of Reference

### 2.1 Tenure:

The term shall be up to 24 weeks for supply from the date of acceptance of the Purchase order/ Notice of award of contract and 12 months warranty from issuance of acceptance certificate/receiving by NMRC, unless otherwise terminated by the Parties in accordance with the terms.

### 2.2 Scope of Work:

**2.2.1** Tender includes Supply of Pantograph Carbon Strips for Rolling Stock Department as per below mentioned specifications-

Supply of Pantograph Carbon Strips for Rolling Stock Department

S. No.	Item Name	DETAILED TECHNICAL SPECIFICATIONS			Qty.
1.	Pantograph Carbon Strip	Dimensions (Design Drawing is attached at <b>Annexure- A</b> )	Carrier Length	1150mm	150 Nos.
2.			Carbon Strip Length	1050+(0-1.00mm)	
3.			Width	42 (+1to -2)mm	
4.			Thickness	51.5±1.00mm	
5.		Material	Type	Metalized Carbon Strips compliant to EN50405	

**2.2.2** Edge of the pantograph strip should be sealed with epoxy sealed or equivalent to prevent water ingress. It should have sufficient mechanical tensile strength so that detachment/crimping doesn't occur during complete life of strip.

**2.2.3** The scope of supply under the contract may be reduced/curtailed based on NMRC's requirements as deemed fit. No claim or compensation will be entertained on this account.

**2.2.4** All the Items will be received by Main Stores Department at NMRC Depot. No Payment will be made for any item found defective.

**2.3 Pre-dispatch inspection at Seller premises (Fee/Charges to be borne by the BUYER):**

Before dispatch, the goods will be inspected by NMRC or their Authorized Representative or by Nominated External Inspection Agency (independently or jointly with Buyer) at Seller premises (or at designated place for inspection as declared /communicated by the seller) for their compliance to the specifications. Fee/Charges taken by the External inspection Agency and any external laboratories testing charges shall be borne by the NMRC. For in-house testing, the Sellers will provide necessary facilities. Seller shall notify the NMRC through email about readiness of goods for pre-dispatch inspection and NMRC will notify the Seller about the Authorized Representative/Nominated External Inspection Agency and the date for testing. The goods would be dispatched to NMRC only after clearance in pre-dispatch inspection. NMRC's right of rejection in respect of the goods finally received at his location shall in no way be limited or waived by reason of the goods having previously been inspected, tested and passed by NMRC or its Nominated External Inspection Agency prior to the goods' shipment.

**2.4 Obligation to the Contractor**

If any damages / loss / theft etc. occurs in the NMRC premise, shall be the sole responsibility of the contractor and necessary compensation shall be paid by the contractor to NMRC as per the actual cost assessed by NMRC.

The contractor shall indemnify and hold NMRC harmless from and against all claims, damages, losses and expenses arising out of, or resulting from the works/services under the contract provided by the contractor.

Contractor shall ensure that its personnel shall not at any time, without the consent of NMRC, in writing, divulge or make known any trust, accounts, matter or transaction undertaken or handled by NMRC and shall not disclose to any person information to the affairs of NMRC.

## Supply of Pantograph Carbon Strips for Rolling Stock Department

All necessary reports, records, registers and other information, under the Contract and all other Statutory Laws, shall be deposited by the contractor on demand by NMRC.

Any damage or loss caused by contractor's persons to the property & equipment's of NMRC Ltd. in whatever form may be recovered from the contractor. Contractor shall not be held responsible for the damages/sabotage caused to the property of NMRC due to the trade union / riots / mobs / armed dacoit activities or any other event of force majeure.

Any liabilities arising out of any litigation (including those in consumer courts) due to any act of contractor's personnel shall be directly borne by contractor including all expenses/fines. The concerned contractor's personnel shall attend the court as & when required.

### 3. Section 3: Instructions to Bidders

#### 3.1 General instructions

- a. A bidder shall submit only one bid in the same tendering process. A bidder who submits or participates in, more than one bid will cause all of the proposals in which the bidder has participated to be disqualified.
- b. The Bidder shall initiate, and actively pursue and involve itself in all investigations and enquiries, Corporation feedbacks, information, convening of and attendance at meetings, and in any other activities as are or may be necessary for producing high quality work as per the requirements.
- c. The Bidder shall carry out the services in compliance with the provisions of this Agreement. Any and all changes necessary to ensure that the Bidder's documents conform to the intent and purpose set out in the Agreement, shall be made at the Bidder's own expense. The Bidder represents that it is a professional and experienced company, and hereby agrees to bear full responsibility for the correctness and technical merit of the services performed.
- d. Bidders shall be evaluated on the basis of the Evaluation Criteria specified in this document. Bidders shall be deemed to have understood and agreed that no explanation or justification for any aspect of the Selection Process will be given and that NMRC's decisions are without any right of appeal whatsoever.
- e. Any entity which has been barred by the Central/State Government in India or by any entity controlled by them, from participating in any project, and the bar subsists as on the date of Bid, would not be eligible to submit an e - Bid.
- f. Bidders are encouraged to inform themselves fully about the assignment and the local conditions before submitting the e-Bid by paying a visit to the Corporation and/or by sending written queries to NMRC before the last date for receiving queries/clarifications.
- g. NMRC shall not be liable for any omission, mistake or error on the part of the Bidder in respect of any of the above or on account of any matter or thing arising out of or concerning or relating to e-Bid or the Selection Process, including any error or mistake therein or in any information or data given by NMRC.
- h. **The currency for the purpose of the Proposal shall be the Indian Rupee (INR).**
- i. Bidders shall not have a conflict of interest. All Bidders found to have a conflict of interest shall be disqualified. Bidders shall be considered to have a conflict of interest with one or more parties in this bidding process, if:
  - i. A bidder has been engaged by the Employer to provide consulting services for the preparation related to procurement or implementation of the project;
  - ii. A bidder is any associates/affiliates (inclusive of parent firms) mentioned in sub paragraph above; or

## Supply of Pantograph Carbon Strips for Rolling Stock Department

- iii. A bidder lends, or temporarily second his personnel to firms or organizations which are engaged in consulting services for the preparation related to procurement for an implementation of the project, if the personnel would be involved in any capacity on the same project.

### Cost of Bid Document / e-Tender processing Fee

- a. The bidder shall bear all costs associated with the preparation and submission of its e-Bid and Noida Metro Rail Corporation Ltd. ("NMRC" or "the Corporation"), will in no case be responsible or liable for these costs, regardless of the conduct or outcome of the e-Bid process.
- b. This tender document is available on the web site <http://etender.up.nic.in> or on NMRC website ([www.nmrcnoida.com](http://www.nmrcnoida.com)) to enable the bidders to view, download the e-Bid document and submit e-Bids online up to the last date and time mentioned in e-Tender notice/ e-tender document against this e-Tender. The bidders shall have to pay cost of bid document/ e-Tender processing fee of as mentioned in **Data Sheet** through RTGS/NEFT only payable in favor of Noida Metro Rail Corporation Limited in the A/c No. mentioned in **Data Sheet**. The scanned copy of RTGS/NEFT receipt with transaction Id certified by the same bank must be enclosed along with the e-Bid. This cost of bid document/ e-Tender processing fee as mentioned in **Data Sheet** will be non-refundable. Tender without cost of bid document/ e-Tender processing fee in the prescribed form, will not be accepted.

### Acknowledgement by Bidder

It shall be deemed that by submitting the e-Bid, the Bidder has:

- a. made a complete and careful examination of the e-Bid;
- b. received all relevant information requested from NMRC;
- c. acknowledged and accepted the risk of inadequacy, error or mistake in the information provided in the e-Bid or furnished by or on behalf of NMRC;
- d. satisfied itself about all matters, things and information, necessary and required for submitting an informed Application and performance of all of its obligations there under;
- e. acknowledged that it does not have a Conflict of Interest; and
- f. Agreed to be bound by the undertaking provided by it under and in terms hereof.

### Availability of Bid Document

This Bid document is available on the web site <http://etender.up.nic.in> or on Noida Metro website [www.nmrcnoida.com](http://www.nmrcnoida.com) to enable the Bidders to view, download the e-Bid document and submit e-Bids online up to the last date and time mentioned in e-Bidder notice/ e-Bid document. The Bidder's shall have to pay e-Bid document fee and EMD as mentioned in Data sheet through RTGS/ NEFT on addresses given in data sheet. The scanned copy of RTGS/ NEFT with transaction ID certified by the same bank must be enclosed along with the e-Bid. This e-Bid document fee will be non-refundable. Bid without Bid fee in the prescribe form will not be accepted.

### Clarifications of e-Bid

- a. During evaluation of e-Bid, NMRC may, at its discretion, ask the Bidder for a clarification of his/her e-Bid. The request for clarification shall be in writing.
- b. Any queries or request for additional information concerning this RFP shall be submitted in writing or by fax and e-mail to the JGM/Stores, NMRC. The envelopes/ communication shall clearly bear the following identification/ title: "**Queries/ Request for Additional Information: RFP for Supply of Pantograph Carbon Strips for Rolling Stock Department**". The responses will be posted to all such queries on the official website [www.nmrcnoida.com](http://www.nmrcnoida.com). NMRC reserves the right not to respond to any questions or provide any clarifications, in its sole discretion, and nothing in this Clause shall be taken or read as compelling or requiring

Supply of Pantograph Carbon Strips for Rolling Stock Department

NMRC to respond to any question or to provide any clarification. A pre- submission meeting shall be called on the date mentioned in **Data Sheet** at NMRC Office. Any change corresponding to date, if any, shall be communicated to the **Bidder vide NMRC/ e- Tendering website**.

- c. In case the Bidder seeks for any queries, he shall send letter or e-mail to the correspondence **address given in Data Sheet**.
- d. **However, NMRC shall not entertain any correspondence from the Bidders during the period of e- Bid opening to selection of the successful Bidder.** Any wrong practice shall be dealt in accordance with the terms and conditions of the RFP.

- e. The Bidder is advised to visit and examine the Site of Works and its surroundings and obtain for himself on his own responsibility all information that may be necessary for preparing the Tender and entering into a contract for the proposed work. The costs of visiting the Site shall be borne by the Bidder. It shall be deemed that the Contractor has undertaken a visit to the Site of Works and is aware of the site conditions prior to the submission of the tender documents.
- f. The Bidder and any of his personnel will be granted permission by the Employer to enter upon his premises and lands for the purpose of such inspection, but only upon the express condition that the Bidder, and his personnel, will release and indemnify the Employer and his personnel from and against all liability in respect thereof and will be responsible for death or personal injury, loss of or damage to property and any other loss, damage, costs and expenses incurred as a result of the inspection.

#### **Amendment of e-Bid Document**

- a. At any time prior to the deadline for submission of e-Bid, NMRC may, for any reason, whether at its own initiative or in response to a clarification requested by a prospective Bidder, modify the e-Bid document by amendments. Such amendments shall be uploaded on the e-procurement website <http://etender.up.nic.in> or NMRC's website [www.nmrcnoida.com](http://www.nmrcnoida.com). The relevant clauses of the e-Bid document shall be treated as amended accordingly.
- b. It shall be the sole responsibility of the prospective Bidder to check the web site <http://etender.up.nic.in> and NMRC's website [www.nmrcnoida.com](http://www.nmrcnoida.com) from time to time for any amendment in the e-Bid documents. In case of failure to get the amendments, if any, NMRC shall not be responsible for it.
- c. In order to allow prospective e-Bids a reasonable time to take the amendment into account in preparing their e-Bids, NMRC, at the discretion, may extend the deadline for the submission of e-Bids. Such extensions shall be uploaded on the e-procurement website <http://etender.up.nic.in> or NMRC's website [www.nmrcnoida.com](http://www.nmrcnoida.com).

### **3.2 Preparation and submission of Bids**

#### **3.2.1 Language of e-Bid**

The e-Bid prepared by the Bidder, as well as all correspondence and documents relating to the e-Bid exchanged by the Bidder and NMRC shall be written in English language. Only English numerals shall be used in the e-Bid. The correspondence and documents in any other language must be accompanied by transcripts verified by the Embassy of Home Country or equivalent.

#### **3.2.2 Documents constituting the e-Bid**

**The e-Bid prepared by the Bidder shall comprise the following components: a.**

##### **Technical e-Bid- Technical e-Bid will comprise of -**

- i. **Fee details** - Details of Bid processing fee and prescribed EMD
- ii. **Eligibility details** - Includes copies of required documents in PDF format justifying that the Bidder is qualified to perform the contract if his/her bid is accepted and the Bidder has financial & technical capability necessary to perform the contract and meets the criteria outlined in the Qualification requirement and technical specification and fulfil all the conditions of the contract.
- iii. **Technical evaluation** - Details of all documents needed for technical evaluation as mentioned in this RFP

**b. Financial e-Bid -**

- i. Price bid** – Bill of Quantities in XLS format to be filled in after downloading from the e-Procurement website for this e-tender (<http://etender.up.nic.in>). There shall be a single financial quote for the package for which the bid is submitted.

**3.2.3 Documents establishing Bidder's Qualification**

- a.** The Bidder shall furnish, as part of its technical e-Bid, documents establishing the Bidder's qualification to perform the contract if its e-Bid is accepted. The documentary evidence should be submitted by the Bidder electronically in the PDF format.
- b.** The documentary evidence of Bidder's qualification to perform the contract if its e-Bid is accepted shall be as per qualification requirements specified in e-Bid document.

**3.2.4 E-Bid form**

The Bidder shall complete the e-Bid form and the appropriate price schedule/BOQ furnished in the e-Bid document.

**3.2.5 E-Bid Currency**

Prices shall be quoted in Indian Rupees only.

**3.2.6 Formats and Signing of e-Bid**

- a.** The Bidder shall prepare one electronic copy of the technical e-Bid and financial e-Bid separately.
- b.** The e-Bid document shall be digitally signed, at the time of uploading, by the Bidder or a person or persons duly authorized to bind the Bidder to the contract. The later authorization shall be indicated by a scanned copy of written power-of attorney accompanying the e-Bid. All the pages/documents of the e-Bid that are to be uploaded shall be digitally signed by the person authorized to sign the e-Bid.
- c.** Bidders should provide all the information as per the RFP and in the specified formats. NMRC reserves the rights to reject any proposal that is not in the specified formats.
- d.** In case the Bidders intends to provide additional information for which specified space in the given format is not sufficient, it can be furnished in duly stamped and signed PDFs.

**3.2.7 Deadline for submission of e-Bid**

E-Bid (Technical and financial) must be submitted by the Bidder at e-procurement website <http://etender.up.nic.in> not later than the time specified on the prescribed date (as the server time displayed in the e-procurement website). NMRC may, at its discretion, extend this deadline for submission of e-Bid by amending the e-Bid document, in which case all rights and obligations of NMRC and Bidders previously subject to the deadline will thereafter be subject to the deadline as extended.

**3.2.8 Submission of e-Bid**

- a.** The bid submission module of e-procurement website <http://etender.up.nic.in> enables the Bidders to submit the e-Bid online in response to this e-Bid published by NMRC.
- b.** Bid submission can be done only from the bid submission start date and time till the bid submission end date and time given in the e-Bid. Bidders should start the bid submission process well in advance so that they can submit their e-Bid in time.
- c.** The Bidder should submit their e-Bid considering the server time displayed in the e-procurement website. This server time is the time by which the e-Bid submission activity will be allowed till the permissible time on the last/end date of submission indicated in the eBid schedule.

- d. Once the e-Bid submission date and time is over, the Bidders cannot submit their e-Bid. For delay in submission of e-Bid due to any reasons, the Bidders shall only be held responsible.

**3.2.9 The Bidders have to follow the following instructions for submission of their e-Bid:**

- a. For participating in e-Bid through the e-Bidding system it is necessary for the Bidders to be the registered users of the e-procurement website <http://etender.up.nic.in>. The Bidders must obtain a user login Id and password by registering themselves with U.P. Electronics Corporation Ltd. Lucknow if they have not done so previously for registration.

- b. In addition to the normal registration, the Bidder has to register with his/her digital signature certificate (DSC) in the e-Bidding system and subsequently he/she will be allowed to carry out his/her e-Bid submission activities. Registering the digital signature certificate (DSC) is a one-time activity. Before proceeding to register his/her DSC, the Bidder should first log on to the e-Bidding system using the user login option on the home page with the login Id and password with which he/she has registered.

For successful registration of DSC on e-procurement website <http://etender.up.nic.in> the Bidder must ensure that he/she should possess class-2/class-3 DSC issued by any certifying authorities approved by controller of certifying authorities, Government of India, as the e-procurement website <http://etender.up.nic.in> is presently accepting DSC issued by these authorities only. The Bidder can obtain user login Id and perform DSC registration exercise given above even before the e-Bid submission date starts. NMRC shall not be held responsible if the Bidder tries to submit his/her e-Bid at the moment before end date of submission but could not submit due to DSC registration problem.

- c. The Bidder can search for active Bids through "search active tenders" link, select a Bid in which he/she is interested in and then move it to 'My Tenders' folder using the options available in the e-Bid submission menu. After selecting and the Bid, for which the Bidder intends to e-Bid, from "My tenders" folder, the Bidder can place his/her e-Bid by clicking "pay offline" option available at the end of the view Bid details form. Before this, the Bidder should download the e-Bid document and price schedule/bill of quantity (BOQ) and study them carefully. The Bidder should keep all the documents ready as per the requirements of e-Bid document in the PDF format except the price schedule /bill of quantity (BOQ) which should be in the XLS format (excel sheet).
- d. After clicking the 'pay offline' option, the Bidder will be redirected to terms and conditions page. The Bidder should read the terms & conditions before proceeding to fill in the Bid fee and EMD offline payment details. After entering and saving the Bid fee and EMD details form so that "bid document preparation and submission" window appears to upload the documents as per technical (fee details, qualification details, e-Bid form and technical specification details) and financial (e-Bid form and price schedule/BOQ) schedules/packets given in the Bid details. The details of the RTGS/NEFT should tally with the details available in the scanned copy and the date entered during e-Bid submission time otherwise the e-Bid submitted will not be accepted.
- e. Next the Bidder should upload the technical e-Bid documents for fee details (e-Bid fee and EMD), Qualification details. Before uploading, the Bidder has to select the relevant digital signature certificate. He may be prompted to enter the digital signature certificate password, if necessary. For uploading, the Bidder should click "browse" button against each document label in technical and financial schedules/packets and then upload the relevant PDF/XLS files already prepared and stored in the Bidder's computer. The required documents for each document label of technical ( fee details, qualification details, e-Bid form and technical specification details) and financial ( e-Bid form and price schedule/BOQ) schedules/packets can be clubbed together to make single different files for each label.
- f. The Bidder should click "Encrypt" next for successfully encrypting and uploading of required documents. during the above process, the e-Bid document are digitally signed using the DSC of the Bidder and then the documents are encrypted/locked electronically with the DSC's of

the bid openers to ensure that the e-Bid documents are protected, stored and opened by concerned bid openers only.

- g. After successful submission of e-Bid document, a page giving the summary of e-Bid submission will be displayed confirming end of e-Bid submission process. The Bidder can take a printout of the bid summary using the "print" option available in the window as an acknowledgement for future reference.
- h. NMRC reserves the right to cancel any or all e-Bids without assigning any reason.

**3.2.10 Late e-Bid**

- a. Bids received by NMRC after the specified time on the Bid Due Date shall not be eligible for consideration and shall be summarily rejected.
- b. The server time indicated in the bid management window on the e- procurement website <http://etender.up.nic.in> will be the time by which the e-Bid submission activity will be allowed till the permissible date and time scheduled in the e-Bid.
- c. Once the e-Bid submission date and time is over, the Bidder cannot submit his/her e-Bid. Bidder has to start the bid submission well in advance so that the submission process passes off smoothly. The Bidder will only be held responsible if his/her e-Bid is not submitted in time due to any of his/her problems/faults, for whatsoever reason, during e-Bid submission process.

**3.2.11 Withdrawal and resubmission of e-Bid**

- a. At any point of time, a Bidder can withdraw his/her e-Bid submitted online before the bid submission end date and time. For withdrawing the Bidder should first log in using his/her login id and password and subsequently by his/her digital signature certificate on the e-procurement website <http://etender.up.nic.in>. The Bidder should then select "My bids" option in the bid submission menu. The page listing all the bids submitted by the Bidder will be displayed. Click "View" to see the details of the bid to be withdrawn. After selecting the "bid withdrawal" option the Bidder has to click "Yes" to the message "Do you want to withdraw this bid?" displayed in the bid information window for the selected bid. The Bidder also has to enter the bid withdrawing reasons and upload the letter giving the reasons for withdrawing before clicking the "Submit" button. The Bidder has to confirm again by pressing "OK" button before finally withdrawing his/her selected eBid.
- b. No e-Bid may be withdrawn in the interval between the deadline for submission of e-Bids and the expiration of period of e- bid validity. Withdrawal of an e-Bid during this interval may result in the forfeiting of Bidder's e-Bid security.
- c. The Bidder can re-submit his/her e-Bid as when required till the e-Bid submission end date and time. The e-Bid submitted earlier will be replaced by the new one. The payment made by the Bidder earlier will be used for revised e-Bid and the new e-Bid submission summary generated after the successful submission of the revised e-Bid will be considered for evaluation purposes. For resubmission, the Bidder should first log in using his/her login Id and password and subsequently by his/her digital signature certificate on the e-procurement website <http://etender.up.nic.in>. The Bidder should then select "My bids" option in the bid submission menu. The page listing all the bids submitted by the Bidder will be displayed. Click "View" to see the detail of the e-Bid to be resubmitted. After selecting the "bid resubmission" option, click "Encrypt & upload" to upload the revised e-Bids documents.
- d. The Bidder can submit their revised e-Bids as many times as possible by uploading their e-Bid documents within the scheduled date & time for submission of e-Bids.
- e. No e-Bid can be resubmitted subsequently after the deadline for submission of e-Bids.

**3.2.12 NMRC's right to accept any e-Bid and to reject any or all e-Bids.**

- a. Notwithstanding anything contained in this e-Bid, NMRC reserves the right to accept or reject any Bid and to annul the Selection Process and reject all Bids, at any time without any liability or any obligation for such acceptance, rejection or annulment, and without assigning any reasons thereof.

- b. NMRC reserves the right to reject any Bid if:
  - At any time, a material misrepresentation is made or uncovered, or
  - The Bidder does not provide, within the time specified by NMRC, the supplemental information sought by NMRC for evaluation of the e-Bid.
- c. Such misrepresentation/ improper response may lead to the disqualification of the Bidder. If such disqualification /rejection occurs after the e-Bid have been opened and the highest-ranking Bidder gets disqualified / rejected, then the NMRC reserves the right to consider the next best Bidder, or take any other measure as may be deemed fit in the sole discretion of NMRC, including annulment of the Selection Process.

#### **3.2.13 Period of validity of e-Bid**

- a. e-Bid shall remain valid for 180 days after the date of e-Bid opening prescribed by NMRC. An e-Bid valid for a shorter period shall be rejected by NMRC as non-responsive.
- b. In exceptional circumstances, NMRC may solicit the Bidder's consent to an extension of the period of e-Bid validity. The request and the response thereto shall be made in writing.

#### **3.2.14 Correspondence with the Bidder**

- a. Save and except as provided in this e-Bid, NMRC shall not entertain any correspondence with any Bidder or its Technical Partners in relation to acceptance or rejection of any e-Bid.
- b. No Bidders or its Technical Partners shall contact NMRC on any matter relating to his e-Bid from the time of Bid opening to the time contract is awarded.
- c. Any effort by the Bidder or by its Technical Partners to influence NMRC in the Bid evaluation, bid comparison or contract award decisions, may result in the rejection of his Bid.

### **3.3 Earnest Money Deposit**

#### **3.3.1 Earnest money deposit (EMD)**

- a. The bidder shall furnish, as part of its e-Bid, an e-Bid security/ EMD as stated in Data Sheet in form of RTGS/NEFT only in favour Noida Metro Rail Corporation Limited in the A/c No. mentioned in **Data Sheet**. The scanned copy of RTGS/NEFT receipt of Security/ EMD with transaction Id certified by the same bank must be enclosed along with the e-Bid. Tender without Earnest Money in the prescribed form, will not be accepted.
- b. Bidders submitting bids for more than one package shall be required to submit EMD for each package as mentioned in **Data Sheet** for which bid is submitted.
- c. Any e-Bid not secured in accordance with above shall be treated as non-responsive and rejected by NMRC.
- d. Unsuccessful Bidder's EMD will be returned within 45 days after conclusion or discharge of the tender.
- e. No interest will be paid by the Purchaser on the Earnest Money Deposit.
- f. The successful Bidder's e-Bid EMD will be adjusted with Performance Bank Guarantee, if applicable, to be submitted by the Bidder upon signing the contract.
- g. The EMD may be forfeited:
  - i. If Bidder (a) withdraws its e-Bid during the period of e-Bid validity specified by the Bidder on the e- bid form: or (b) does not accept the correction of errors or (c) modifies its e-Bid price during the period of e-Bid validity specified by the Bidder on the form.
  - ii. In case of a successful Bidder, if the Bidder fails to sign the contract with the Corporation.

### **3.4 Opening and Evaluation of Bids**

#### **3.4.1 Opening of technical e-Bid by NMRC**

- a. NMRC will open all technical e-Bids, in the presence of Bidder's representatives who choose to attend on the prescribed date of opening at NMRC Office. The Bidder's representatives who are present shall submit the letter to NMRC on the letter head of the company stating that the representative (name) is authorized to attend the meeting (Please note – The representative is required to carry a copy during pre-bid and other related meetings as well). He / She shall sign a register evidencing their attendance at NMRC. In the event of the specified date e-Bid opening being declared a holiday for the Corporation, the e –bids shall be opened at the appointed time and place on the next working day.
- b. The Bidder who is participating in e-Bid should ensure that the RTGS/NEFT of Bid Processing Fee and EMD must be submitted in the prescribed account of NMRC within the duration (strictly within opening & closing date and time of individual e-Bid) of the work as mentioned in Bid notice, otherwise, in any case, e-Bid shall be rejected.
- c. The Bidders names and the presence or absence of requisite e-Bid security and such other details as NMRC at its discretion may consider appropriate, will be announced at the opening.

#### **3.4.2 Opening of financial e-Bid**

- a. After evaluation of technical e-Bid, through the evaluation committee NMRC shall notify those Bidders whose technical e-Bids were considered non-responsive to the conditions of the contract and not meeting the technical specifications and qualification requirements indicating that their financial e-Bids will not be opened.
- b. NMRC will simultaneously notify the Bidders, whose technical e-Bids were considered acceptable to the Corporation. The notification may be sent by e-mail provided by Bidder.
- c. The financial e-Bids of technically qualified Bidders shall be opened in the presence of technically qualified bidders who choose to attend. The date and time for opening of financial bids will be communicated to the technically qualified Bidders subsequently after completion of technical bids evaluation through e-mail provided by the Bidder.

#### **3.4.3 Correction of Errors**

- a. Financial Bids determined to be responsive will be checked by NMRC for any arithmetic errors. Where there is a discrepancy between the rate quoted in the Financial Bid, in figures and in words, the amount in words will prevail over the amounts in figures, to the extent of such discrepancy.
- b. The amount stated in the Financial Bid will be adjusted by NMRC in accordance with the above procedure for the correction of errors and shall be considered as binding upon the Bidder. If the Bidder does not accept the corrected quoted rate of e-Bid, his e-Bid will be rejected, and his Bid Security shall be liable for forfeiture.

#### **3.4.4 Examination of e-Bid document**

- a. The NMRC will examine the e-Bid to determine if:
  - i. They are complete; ii. They meet all the conditions of the contract; iii. The required e-Bid Processing fee, EMD and other required documents have been furnished; iv. The documents have been properly digitally signed; and v. The e-Bids are in order.
- b. Any e-Bid or e-Bids not fulfilling these requirements shall be rejected.

**3.4.5 Contacting NMRC**

- a. No Bidder shall contact NMRC on any matter relating to his/her e-Bid, from the time of the e-Bid opening to the time the contract is awarded. If the Bidder wishes to bring additional information to the notice of NMRC, he/she can do so in writing.
- b. Any effort by a Bidder to influence NMRC in its decisions on e-Bid evaluation, e- bid comparison or contract award may result in rejection of the Bidder's e-Bid.
- c. In the event of any information furnished by the Bidder is found false or fabricated, the minimum punishment shall be debarring /blacklisting from Noida Metro works and legal proceeding can also be initiated. EMD of such bidders will be forfeited.

**3.4.6 Confidentiality**

- a. Information relating to the examination, clarification, evaluation, and recommendation for the Bidders shall not be disclosed to any person who is not officially concerned with the process or is not a retained professional advisor advising NMRC in relation to or matters arising out of, or concerning the Bidding Process. Any effort by a Bidder to exert undue or unfair influence in the process of examination, clarification, evaluation and comparison of Proposal shall result in outright rejection of the offer, made by the said Bidder.
- b. NMRC shall treat all information, submitted as part of Bid, in confidence and shall require all those who have access to such material to treat the same in confidence. NMRC may not divulge any such information unless it is directed to do so by any statutory entity that has the power under law to require its disclosure or is to enforce or assert any right or privilege of the statutory entity and/ or NMRC or as may be required by law or in connection with any legal process.

**3.5 Award of Contract**

**3.5.1 Award Criteria**

- a. NMRC will award the contract as per evaluation criteria stated in the RFP Document.
- b. NMRC will award the contract to the successful Bidder whose bid has been determined to be responsive to all the conditions of the contract and meeting the eligibility requirement of the bidding document.

**3.5.2 Purchase Order**

- a. Prior to the expiration of the period of Bid validity, NMRC will issue Purchase order to the successful Bidder in writing, by letter/mail.
- b. The successful bidder shall have to provide unconditional acceptance of the Purchase order/ Notice of award of contract within 10 days from the date of issue of Purchase order. Contractor is required to submit Performance Bank Guarantee / Security Deposit within 30 days from the date of acceptance of Purchase order. Upon the receipt of the unconditional acceptance of Purchase order along with Performance Bank Guarantee / Security Deposit, a legally binding contract shall be deemed to have commenced between NMRC and successful bidder.

**3.5.3 NMRC's right to accept any Bid and to reject any or all Bids**

NMRC reserves the right to accept or reject any Bid, and to annul the Bid process at any time prior to contract award, without thereby incurring any liability to the affected bidder or bidders.

**3.5.4 Signing of contract**

Upon acceptance of the Purchase Order by the bidder, a legally binding contract shall be deemed to have commenced between NMRC and the bidder. However, the bidder shall be required to execute a formal agreement along with all necessary documents as per RFP with NMRC within 45

Supply of Pantograph Carbon Strips for Rolling Stock Department

days from the acceptance of Purchase order/ NOA as per format provided in the RFP document.  
The cost of Agreement and notarization charges shall be borne by the bidder.

## 4. Section 4: Eligibility, Evaluation and Selection Process

### 4.1 Eligibility Criteria

The Bidder's competence and capability is proposed to be established by the following parameters. The Bidder should meet all the criteria given in this section.

- a) Sole proprietorship, registered partnership firm (including LLP), public limited company, private limited company can submit the Bid. The firms and the companies should be registered in India.
- b) The Bidder should have completed in India during last 7 (Seven) year's period ending last day of month previous to the one in which the bids are invited should be either of the following:
  - i. One order of similar nature of value not less than Rs. 26.76 lakh (Rupees Twenty-Six Lakh Seventy-Six Thousand only) or ii. Two orders of similar nature of value not less than Rs 16.72 lakh (Rupees Sixteen Lakh Seventy-Two Thousand Only) each or iii. Three orders of similar nature of value not less than Rs 13.38 lakh (Rupees Thirteen Lakh Thirty-Eight Thousand Only) each.

**Definition of Similar Work: Works involving supply of Pantograph Carbon Strips to any Metro/Railway system, either in India or internationally.**

- c) **Bidders are required to enclose copies of the work orders and work completion certificate in support of the same with the Technical-Bid. Work completion certificate clearly indicating the nature/scope of work, actual completion cost and actual date of completion for such work without proper and valid certificates from the Employers, bid will be rejected.**
- d) The Bidder should have minimum average annual turnover of Rs. 33.45 Lakh (Rupees Thirty-Three Lakh Forty-Five Thousand only) in the last 3 (three) audited Financial Years (2022-23, 2023-24, 2024-25) preceding the Bid Due Date.
- e) Profit before tax should be positive in at least 1 (one) year; out of the last 3 (three) audited financial years ended on 31st March 2025.
- f) The Bidder or its owners/partners have not been blacklisted/ banned/ declared ineligible for corrupt and fraudulent practices by the Government of India/ any State Government/ Government Agency and court of law and contracts have been terminated/ foreclosed by any company/department due to nonfulfillment of Contractual obligation in last 5 (five) financial years.
- g) The Bidder should be registered with the Goods and Services Tax Authority.
- h) Bidders are required to provide the Technical Data Sheet along with their bids.

**The Bidder shall also furnish the following documentary proof:**

- a. For above criteria 4.1a
  - i. Registration certificate of the firm/ Partnership deed/ certificate of incorporation/affidavit for sole proprietorship, etc.
- b. For above criteria 4.1b & c
  - i. Form 3: Work Experience with documentary evidence
- c. For above criteria 4.1d & e
  - i. Form 4: Financial Capability Details
  - ii. A copy of the Audited balance sheets and Profit and Loss Statements for the last 3 (three) financial years (FY 2022-23, 2023-24, 2024-25).
  - iii. Self-attested copy of PAN, ITR (For last 3 audited FY's) ending on 31st March, 2025.
- d. For above criteria 4.1 g
  - i. Copy of GST registration certificate

- e. For above criteria 4.1f
  - i. Form 6: Undertaking

#### **4.2 Information of the Technical and Financial Proposal**

- i. The financial proposal of only technically qualified Bidder shall be opened for evaluation.
- ii. The Bidder satisfying the criteria under shall be considered as qualified.

#### **4.3 Purchase Order**

- i. Prior to the expiration of the period of Bid validity, NMRC will issue Purchase order to the successful Bidder in writing, by letter/mail.
- ii. The successful bidder shall have to provide unconditional acceptance within 10 days of receipt of the Purchase order/Notice of award and Performance Bank Guarantee / Security Deposit within 30 days from the date of acceptance of Purchase order/Notice of award. iii. The Successful Bidder shall supply the required items within the time period as mentioned in Purchase order or such extended period as may be decided by the Corporation.
- iv. Failure of the Successful Bidder to comply with the requirement of acknowledgement of Purchase Order shall constitute sufficient grounds for the annulment of the Purchase Order, and forfeiture of the bid security.
- v. The Purchaser/Buyer reserves the right to increase or decrease the quantity up to 25% of the quantity offered by the successful bidder. The bidder is bound to accept the increase or decrease in the tendered quantity up to 25% under this clause without any change in unit price.
- vi. In case the variation in individual items or the group of items as stipulated above, is more than 25% on plus side, the rate for the varied quantity beyond 25% shall be negotiated between the NMRC and the Contractor and mutually agreed rates arrived at before actual execution of the extra quantity. In case the contractor executes the extra quantity without written approval of the NMRC with specific instructions to execute pending the finalization of rates, the payment shall be made at contract rate only. In the event of disagreement, the Engineer shall fix such rates of price as are, in his opinion appropriate and shall notify the Contractor accordingly, with a copy to the Employer. Until such time as rates or prices are agreed or fixed, the Engineer shall determine provisional rates or prices to enable on account payments to the Contractor. Alternatively, in the event of disagreement, the Contractor shall have no claim to execute extra quantities/new items and the Engineer shall be free to get such additional quantities beyond 25% new items executed through any other agency. However, if the Engineer or the Employer so directs the Contractor shall be bound to carry out any such additional quantities beyond the limits stated above original quantities and or new items and the disagreement or the difference regarding rates to be paid for the same shall be settled in the manner laid down under the conditions for the settlement of dispute.

#### **4.4 Performance Bank Guarantee / Security Deposit**

- i. To fulfil the requirement of performance bank guarantee during the implementation period, the Successful Bidder (herein referred to as the "Contractor") shall deposit 5% of the Contract Price in form of NEFT/RTGS, FDR or unconditional and irrevocable Bank Guarantee bond as per Form -13 of this RFP, issued by a scheduled bank of Delhi-NCR in Favor of Noida Metro Rail Corporation Limited valid for 24 months within 30 days of acceptance of Purchase order/Notice of Award. The performance guarantee shall be valid for a period up to 6 months beyond the work end date. EMD amount of successful bidder shall be adjusted in the performance bank guarantee, if applicable. For unsuccessful bidder, EMD shall be refunded without any interest. In case of extension of tenure by 6 months, the performance bank guarantee shall be extended by 6 months or such increased period as well the performance guarantee shall be extended or renewed in advance before expiry of existing guarantee. Failure to submit the PBG within 30 days from the date of acceptance of Purchase order/ NOA, a penal interest of 15% per annum shall be charged for the period i.e. from date of acceptance of NOA to the date of submission of PBG. In case Contractor fails to submit the PBG beyond 60 days from the date of acceptance to Purchase order/

NOA, the contract shall be annulled duly forfeiting Tender security and other dues. In case of any extension is sought for PBG, extension will be only after approval from

NMRC.

- ii. It is to note that if contract value increases by more than 25% of the original contract value, the performance bank guarantee shall be increased accordingly. However same PBG will hold good for any variation up of 25% of original contract.
- iii. A contract agreement will have to be signed by the contractor at his cost on proper stamp paper. Without performance guarantee by contractor, contract agreement shall not be signed.
- iv. The Bank guarantee must be issued by a bank branch located in Delhi/NCR, Noida and Greater Noida region only. The performance bank guarantee shall be extended and renewed in advance before expiry of existing guarantee.
- v. NMRC reserves the right for deduction of NMRC dues from Contractor's Performance Bank Guarantee/ Security Deposit (interest free) for –
  1. Any penalty imposed by NMRC for violation of any terms and conditions of agreement committed by the Contractor.
  2. Any amount which NMRC becomes liable to the Government/Third party due to any default of the Contractor or any of his director/ employees/ representatives/ servant/ agent, etc.
  3. Any payment/ fine made under the order/judgment of any court/consumer forum or law enforcing Contractor or any person duly empowered in his behalf.
  4. Any outstanding payment/ claims of NMRC remained due after completion of relevant actions as per agreement.
- vi. Once the amount under above Clause is debited, the Contractor shall replenish the Security Deposit/Performance Bank Guarantee to the extent the amount is debited within 15 days period, failing which, it shall be treated as Contractor Event of Default and will entitle NMRC to deal with the matter as per the provisions of RFP and Contract Agreement.

#### **4.6 Contact during Proposal Evaluation**

- i. Proposals shall be deemed to be under consideration immediately after they are opened and until such time NMRC makes official intimation of award/ rejection to the Bidders. While the Proposals are under consideration, Bidders and/ or their representatives or other interested parties are advised to refrain from contacting by any means, NMRC and/ or their employees/ representatives on matters related to the Proposals under consideration till the time Contract is awarded
- ii. Any effort by a Bidder to influence NMRC in its decisions on Bid evaluation, bid comparison or contract award may result in rejection of the Bidder's Bid.
- iii. In the event of any information furnished by the agency is found false or fabricated the minimum punishment shall be debarred/ blacklisting and the legal proceeding may also be initiated. iv. If the Bidder wishes to bring additional information to the notice of NMRC, he/she can do so in writing. All correspondence/ enquiry should be submitted to the following in writing by fax/ post/courier:  
JGM/Stores  
Noida Metro Rail Corporation (NMRC) Limited  
Block-III, 3rd Floor, Ganga Shopping Complex, Sector-29,  
Noida -201301  
District Gautam Buddha Nagar, Uttar Pradesh  
Email: nmrcafc@gmail.com
- v. No interpretation, revision, or other communication from NMRC regarding this solicitation is valid unless in writing and signed by the competent authority from NMRC.

#### **4.7 Financial Terms**

#### 4.7.1 Payment Terms

The standard payment terms subject to recoveries, if any by way of Liquidated damages (LD) will be as under:

- a. 100% Payment will be made after-
  - i. Delivery of Pantograph Carbon Strips at Main Stores (DCOS) Building, NMRC Depot.
  - ii. Final Acceptance/Receiving by NMRC after installation and commissioning at NMRC site.
  - iii. Submission of delivery Challan & E-way bill.
  - iv. Copies of bills in original with relevant supporting documents.
- b. No Payment shall be made in advance.
- c. No payment shall be made for the items rejected.
- d. GST will be paid only on the production of GST paid Challan or its reflection in the GSTR 2A on the GST portal of NMRC.
- e. Statutory deductions shall be made as per prevalent statutes.

**4.7.2. Liquidated Damages:** If the contractor fails to deliver/commission/install any or all of the Goods/Services within the original/fixed period(s) as specified in the Purchase order, the NMRC will be entitled to deduct/recover the Liquidated Damages for the delay, unless covered under Force Majeure conditions aforesaid, @ 0.5% of the contract value of delayed quantity per week or part of the week of delayed period as pre estimated damages not exceeding 10% of the contract value of delayed quantity without any controversy/dispute of any sort whatsoever.

## **5. Section 5: General Conditions of Contract (GCC)**

**These conditions shall be part of the contract agreement.**

### **5.1 General Provisions**

#### **5.1.1 Governing law and jurisdiction**

These general conditions shall be governed by and construed in accordance with the laws in the territory of India. Irrespective of the place of delivery and the place of payment under the contract, the contract shall be deemed to have been made at the place in India from where the acceptance of tender has been issued. Any dispute arising between the parties or arising out of this project or these terms shall be subject to the exclusive jurisdiction of, and venue in, the District court located in Gautam Budh Nagar, Uttar Pradesh, India.

#### **5.1.2 Notices**

Any notice, request or consent required or permitted to be given or made pursuant to these general conditions shall be in writing. Any such notice, request or consent shall be deemed to have been given or made when delivered in person to an authorized representative of the party to whom the communication is addressed, or when sent to such party at the mentioned address.

#### **5.1.3 Authorized Representatives**

Any action required or permitted to be taken, and any document required or permitted to be executed under these general conditions by the Corporation or the Successful Bidder may be taken or executed by the officials as formally designated by each party.

#### **5.1.4 Taxes and Duties**

- a. The Agency shall bear and pay all taxes, duties, levies and charges assessed on the Agency, its Sub Agencies or their employees by all municipal, state or national government authorities in connection with the Facilities in and outside India, the amount of which is deemed to have been included in the Contract Price.
- b. The Agency shall ensure full compliance with tax laws of India with regard to this contract and shall be solely responsible for the same. He shall keep the Employer fully indemnified against liability of tax, interest, penalty etc., of the Agency's in respect thereof, which may arise.

## **5.2 Commencement, Completion, Modification and Termination of Contract**

#### **5.2.1 Effectiveness of Contract**

This Contract shall come into effect on the date the Contract is signed by both the parties and such other later date as discussed and agreed with the Bidder.

#### **5.2.2 Commencement of Services**

The Contractor shall begin carrying out the Services from the date of acceptance of NOA or any such date as specified by the employer.

#### **5.2.3 Expiration of Contract**

Unless terminated earlier pursuant to Clause 5.2.6 hereof, these general conditions shall expire at the end of such time period as given in the time schedule in RFP Document.

### 5.2.4 Modifications or Variations

Any modification or variation of the terms and conditions of these general terms, including any modification or variation of the scope of the Services, may only be made by written agreement between the Parties. However, each Party shall give due consideration to any proposals for modification or variation made by the other Party.

### 5.2.5 Force Majeure

- (i) Definition: For the purpose of these general terms, "Force Majeure" means an event which is beyond the reasonable control of a Party and which makes a Party's performance of its obligations under the Contract impossible or so impractical as to be considered impossible under the circumstances.
- (ii) No Breach of Contract: The failure of a Party to fulfill any of its obligations under the contract shall not be considered to be a breach of, or default under, this Contract insofar as such inability arises from an event of Force Majeure, provided that the Party affected by such an event (a) has taken all reasonable precautions, due care and reasonable alternative measures in order to carry out the terms and conditions of this Contract, and (b) has informed the other Party as soon as possible about the occurrence of such an event.
- (iii) Extension of Time: Any period within which a Party shall, pursuant to this Contract, complete any action or task, shall be extended for a period equal to the time during which such Party was unable to perform such action as a result of Force Majeure.
- (iv) Payments: During the period of their inability to perform the Services as a result of an event of Force Majeure, the Agency shall be entitled for time extension for such period.
- (v) Conditions like Pandemic/Lockdown (e.g. in COVID-19) will be treated as Force Majeure. During the period of Non-performance in these conditions, contractor will not be billed and Extension of Time will be given for such period.

### 5.2.6 Termination of Contract

If the Contractor fails to carry out any of his obligations, or if the Contractor is not executing the Works in Accordance with the Contract, the Engineer may give notice to the Contractor requiring him to make good. Such failure and remedy the same within such time as the Employer / Engineer may deem to be reasonable.

The Employer shall be entitled to terminate the Contract if the Contractor or any one of its constituents,

- a. fails to comply with a notice under this clause.
- b. abandons or repudiates the Contract
- c. without reasonable excuse acceptable to the Engineer, fails to commence the Works in accordance with The Contract
- d. Sub-contracts the whole of the Works or assigns the Contract without approval of the Employer
- e. becomes bankrupt or insolvent or goes into liquidation except voluntary liquidation for the purpose of Amalgamation or reconstruction
- f. persistently disregards instructions of the Engineer or contravenes any provisions of the Contract, or
- g. fails to adhere to the agreed programme of work by margin of 10% of the stipulated period or 21 days, whichever is earlier, or fails to complete the Works or parts of the Works within the stipulated or extended period of completion, or is unlikely to complete the whole Work or part thereof within time because of poor record of progress; or
- h. fails to remove materials from the Site, or pull down and replace Work, after receiving notice from the Engineer to the effect that the said materials or Works have been condemned or rejected, or
- i. fails to take steps to employ competent and/or additional staff and labour, or
- j. fails to afford the Engineer or his Representative proper facilities for inspecting the Works or any part thereof, or
- k. indulges in corrupt or fraudulent practices as explained in Clause 5.9

In any one of these events or circumstances, the Employer may upon giving 14 days' notice to the Contractor, Terminate the Contract and expel the Contractor from the Site. However, in case of sub-paragraph (e) or (k), the Employer may by notice of 7 days to the Contractor, terminate the Contract immediately.

If the Agency fails to provide the services within the period fixed for such services in the contract or as extended or at any time repudiates the contract before the expiry of such period, the employer may terminate the contract without prejudice to his other rights. The total amount of liquidated damages, however, not exceed the **limit of liquidated damages i.e.10 % of total Contract value**, after which contract will be deemed as cancelled & PBG will be encashed by the Employer.

The Employer's decision to terminate the contract shall not prejudice any other rights of the employer under the contract. On Termination of contract due to Contractor's default, the performance Security shall be forfeited by encashing the Bank Guarantee and the balance work shall be got done independently without risk and cost of the failed contractor. The failed contractor shall be debarred from participating in the tender for executing the balance work.

### **5.2.7. Upon Termination of this Agreement for any reason whatsoever**

Upon termination of this Agreement shall not release contractor to pay any sums then owing to the other party nor from the obligation to perform or discharge any liability that had been incurred prior thereto.

### **5.3 Insolvency and Breach of Contract**

The Employer may at any time, issue notice in writing summarily terminate the contract without compensation to the Agency in any of the following events, that is to say –

- a. If the Agency being an individual or a firm - Any partner thereof, shall at any time, be adjudged insolvent or shall have a receiving order or order for administration of his estate made against him or shall take any proceeding for composition under any Insolvency Act for the time being in force or make any conveyance or assignment of his effects or enter into any assignment or composition with his creditors or suspend payment or if the firm be dissolved under the Partnership Act, or
- b. If the Agency being a company is wound up voluntarily or by the order of a Court or a Receiver, Liquidator, or Manager on behalf of the debenture holders is appointed, or circumstances shall have arisen which entitle the Court or Debenture holders to appoint a Receiver, Liquidator or Manager, or
- c. If the Agency commits any breach of the contract not herein specifically provided for
- d. Provided always that such determination shall not prejudice any right of action or remedy which shall have accrued or shall accrue thereafter to the Employer and provided also the Agency shall be liable to pay to the Employer any extra expenditure he is thereby put to and the Agency shall, under no circumstances, be entitled to any gain on re purchase.

### **5.4 Warranty**

- a. The Bidder shall give warranty that the goods shall be new and free from defects and manufacture shall be of the highest grade and consistent with the established and generally accepted standards for materials of the type ordered.
- b. Warranty of supplied items should be of at least 12 months.
- c. If it becomes necessary for the Agency to replace or renew any defective portion/portions of the item under this clause, the provisions of the clause shall apply to the portion/portions of item's replaced or renewed. If any defect is not remedied within a reasonable time, the Employer may proceed to get the work done at the Agency's risk and expenses, but without prejudice to any other rights which the Employer may have against the Agency in respect of such defects.
- d. Replacement under warranty clause shall be made by the Agency free of all charges at site including freight, insurance and other incidental charges, as the case may be.

### **5.5 Inspection**

The Employer or its representatives or ultimate client shall have the right to inspect and test the goods for their conformity to the specifications as required.

### **5.6 Obligations of the Agency**

- a. The Agency/Bidder shall undertake the Work with due care and diligence in accordance with the Contract.
- b. Engagement of Staff and Labour- Except as otherwise stated in the Specification, the Agency shall ensure/ make arrangements for the engagement of all staff and labour, local or otherwise, and for their payment, transport, etc.

### **5.7Packaging**

The Agency shall be responsible for packing, transporting, receiving, storing and protecting all items and other things required for the Works.

### **5.8 Obligations of employer**

NMRC agrees to provide support to the Agency and undertake to observe, comply with and perform, subject to and in accordance with the provisions of the Agreement and the Applicable Laws.

### **5.9 Fraud and Corrupt Practices**

- a. The Bidders and their respective officers, employees, agents and advisers shall observe highest standard of ethics during Bidding Process and subsequent to issue of NOA and during subsistence of Contract Agreement. Notwithstanding anything to the contrary contained herein, or in the NOA or the Contract Agreement, NMRC may reject a Bid, withdraw the NOA, or terminate the Contract Agreement, as the case may be, without being liable in any manner whatsoever to the Bidder or Agency, as the case may be, if it determines that the Bidder or Agency, as the case may be, has, directly or indirectly or through an agent, engaged in corrupt practice, fraudulent practice, coercive practice, undesirable practice or restrictive practice in the Bidding Process. In such an event, NMRC shall be entitled to forfeit & appropriate Bid Security or Security Deposit (interest free)/ Performance Bank Guarantee, as the case may be, as Damages, without prejudice to any other right or remedy available to NMRC under Bidding Documents and/ or Contract Agreement, or otherwise.
- b. Without prejudice to the rights of NMRC under Clause 5.9 a hereinabove and the rights and remedies which NMRC may have under the NOA or the Contract Agreement, or otherwise if a Bidder or Agency, as the case may be, is found by NMRC to have directly or indirectly or through an agent, engaged or indulged in any corrupt practice, fraudulent practice, coercive practice, undesirable practice or restrictive practice during the Bidding Process, or after the issue of the NOA or the execution of the Contract Agreement, such Bidder or Agency shall not be eligible to participate in any tender or RFP issued by NMRC during a period of 3 (three) years from the date such Bidder is found by NMRC to have engaged, directly or indirectly, in any corrupt practice, fraudulent practice, coercive practice, undesirable practice or restrictive practice.
- c. For the purposes of this Clause, the following terms shall have the meaning herein after respectively assigned to them:
  - i. "corrupt practice" means the offering, receiving, or soliciting, directly or indirectly, of anything of value to influence the action of a public official in the selection process or in contract execution;
  - ii. "fraudulent practice" means a misrepresentation or omission of facts in order to influence a selection process or the execution of a contract;
  - iii. "collusive practices" means a scheme or arrangement between the Agency, with or without the knowledge of the authority, designed to establish prices at artificial, non-competitive levels;
  - iv. "coercive practices" means harming or threatening to harm, directly or indirectly, persons or their property to influence their participation in a procurement process, or affect the execution of a contract

d. Measures to be taken:

The employer shall have right to cancel the engagement of the Agency, if found to be indulged in corrupt, fraudulent, collusive or coercive practices either during the selection process or during the execution of the contract. **5.10 Settlement of Disputes**

**5.10.1. Amicable Settlement**

The Parties agree that the avoidance or early resolution of disputes is crucial for a smooth execution of the Contract and the success of the Project. The Parties shall use their best efforts to settle amicably all disputes arising out of or in connection with this Contract or its interpretation.

**5.10.2 Conciliation**

In the event of any dispute, difference of opinion or dispute or claim arising out of or relating to this License Agreement or breach, termination, shall firstly be attempted to be settled by conciliator appointed/nominated by NMRC on receipt of such requests from either party. The conciliator shall make the settlement agreement. The settlement agreement shall be final and binding on the parties. The settlement agreement shall have the same status and effect of an Arbitration Award.

**5.10.3 Arbitration:**

All disputes related to this agreement contract or claims arising out of or relating to this agreement or breach, termination or the invalidity thereof or any issue whether arising during the progress of services or after the completion or abandonment thereof or any matter directly or indirectly connected with this agreement shall be attempted to be settled by mutual discussion and consultation with parties here of in event of any such disputes or any disputes or claims are not settled in aforesaid manner, then the disputes claim shall be referred for arbitration.

The matter referred to arbitrators appointed by Managing director, NMRC on receipt of such request from either party. Matters to be arbitrated upon shall be referred to a sole arbitrator, if the total value of the claim is up to Rs.50 Lakhs and to a panel of 3 arbitrators for the claims of more than Rs.50 Lakhs. License shall have to choose the sole arbitrator from the panel of 3 and / or one arbitrator from the panel of 5 in case 3 arbitrators are to be appointed. NMRC shall also choose one arbitrator from this panel of 5 and 2 so chosen will choose the 3<sup>rd</sup> arbitrator from the panel only. The arbitrators shall be appointed within a period of 30 days from the date of receipt of written notice/demand of appointment of the arbitrator from either party.

The decision of sole arbitrator / panel of arbitrators shall be binding on all the parties. The cost of arbitration shall be borne by respective parties equally. The venue of such arbitration shall be Noida, UP. The parties agree to comply with the awards resulting from arbitration and waive their rights to any form of appeal insofar as such waiver can validly be made.

**5.10.3 Rules Governing Arbitration Proceedings:**

The arbitration proceedings shall be governed by Indian arbitration and conciliation act 1996, as amended from time to time including provisions in force at the time the references made.

**5.10.4 Jurisdiction of Courts:**

The Court at Gautam Budh Nagar, U.P. shall have the exclusive jurisdiction to try all dispute between the party arising out of this agreement.

## 6. Section 6: Draft Contract Agreement

THIS AGREEMENT made on the..... day of .... 2026 at Noida, District Gautam Buddha Nagar, Uttar Pradesh Between **Noida Metro Rail Corporation Limited** (Hereafter referred to as “NMRC”), a company incorporated under Companies Act 2013, vide corporate identification Number: U60231UP2014SGC066849 and having its registered office at **Block-III, 3rd Floor, Ganga Shopping Complex, Sector-29, Noida -201301**, District Gautam Budh Nagar, Uttar Pradesh, India represented by ..... of the company, by virtue of his designation and authorization by Noida Metro Rail Corporation (hereinafter called as the “Employer”), which expression shall unless excluded by or repugnant to the context or meaning thereof be deemed to include its successors and permitted assigns) of the one part,

**AND**

.....having its registered office at....., represented by (herein after called the “**Contractor**”, which expression shall unless excluded by or repugnant to the context or meaning thereof be deemed to include its successors and permitted assigns) of the other part. WHEREAS the employer desires that the Works/ Services known ..... as the “.....” should be executed by the Contractor, and has accepted a contract by the Contractor for the execution and completion of these Works.

The employer and the Contractor agree as follows:

1. In this Agreement words and expressions shall have the same meanings as are respectively assigned to them in the Contract documents referred to.
2. The following documents shall be deemed to form and be read and construed as part of this Agreement- **Reference:**
  - (i) Tender No. .... Dated.....
  - (ii) Bid Documents duly accepted and submitted by ..... dated.....
  - (iii) The Bidding Documents which include all the Sections specified below:
    - a. Section 1: General Information
    - b. Section 2: Terms of Reference, Scope of work, Particular Specifications
    - c. Section 3: Instructions to Bidders
    - d. Section 4: Eligibility, Evaluation and Selection Process, Special Condition of Contract
    - e. Section 5: General Conditions of Contract (GCC) of NMRC
    - f. Section 6: Draft contract agreement
    - g. Section 7: Forms
  - (iv) Amendments/Corrigendum/Addendum issued by NMRC, if any.
  - (v) Notice of Award( ..... ) issued by NMRC

- (vi) Letter of acceptance of NOA (.....) given by (.....) to NMRC.
- (vii) Any other admitted correspondence documents between NMRC and the Bidder.

**3. Duration of Contract**

The Employer intends to appoint a Contractor to NMRC for a period of 24 weeks for Supply of Pantograph Carbon Strips for Rolling Stock Department plus 12 Months warranty.

**4. Price Schedule**

NMRC shall consider the following Total Contract Price, as quoted by the Contractor as part of financial bid.

- 5. The courts at District Gautam Budh Nagar, Uttar Pradesh shall have the exclusive jurisdiction to try all disputes arising out of this agreement between the parties.
- 6. In consideration of the payments to be made by the Employer to the Contractor as specified in this Agreement, the Contractor hereby covenants with the Employer to execute the Works/ Services and to remedy defects therein in conformity in all respects with the provisions of the Contract and Notice of Award issued. "Any conditions, deviation, assumption, exclusion, suggestion of alternative clauses, request of amendments in conditions & specifications of work submitted by bidders along with his Technical Bid or Financial bid, which is different from the Tender Document, Corrigendum, Addendum uploaded by NMRC on the E-Tender Portal (<http://etender.up.nic.in>) and any other correspondence in this regard, shall not be treated as a part of the contract Agreement & shall not be binding upon NMRC in anyway whatsoever at any stage of work during execution or thereafter."
- 7. The Employer hereby covenants to pay the Contractor in consideration of the execution and completion of the Works/Services, the Contract Price or such other sum as may become payable under the provisions of the Contract at the times and in the manner prescribed by the Contract and NOA.

IN WITNESS where of the parties hereto have caused this Agreement to be executed in accordance with the laws of India on the day, month and year specified above.

For and on behalf of the Contractor For and on behalf of the Employer Signature of the authorized official  
Signature of the authorized official

**Name of the official**

**Name of the official**

Stamp/Seal of the Contractor Stamp/Seal of the Employer

In the presence of:

In the presence of:

Witness1

Sign of Witness 1

Sign of

Name \_\_\_\_\_

Name \_\_\_\_\_

Address \_\_\_\_\_

Address \_\_\_\_\_

Witness 2_ _____ _____ Name _____ Address _____ _____	Sign of Witness 2 Name _____ Address _____ _____	Sign of _____ Name _____ Address _____ _____
---	---	---

## 7. Section 7: Forms

### Form 1: Letter of Proposal Submission

[Location, Date]

To

JGM/Stores  
 Noida Metro Rail Corporation (NMRC) Limited  
 Block-III, 3rd Floor, Ganga Shopping Complex, Sector-29,  
 Noida -201301  
 District Gautam Budh Nagar, Uttar Pradesh

**Subject:** Supply of Pantograph Carbon Strips for Rolling Stock Department

Dear Sir,

We, the undersigned, offer to Supply of Pantograph Carbon Strips for Rolling Stock Department in accordance with your RFP Document dated [Insert Date] and our Proposal. We are hereby submitting our Technical and Financial Proposal. We confirm that we have read the RFP Document in totality and abide by the terms and conditions stated in the document. We acknowledge that we have

- Studied and analyzed and satisfied ourselves about all the requirement of the tender including but not limited to market and market conditions
- Carefully assessed the commerciality of Project and that we will be fully responsible for all its assessment in this regard.

We confirm and declare that no agent, middleman or any intermediary has been, or will be, engaged to provide any services, or any other item or work related to the award and performance of this Contract and declare that no agency commission or any payment which may be construed as an agency commission has been, or will be, paid and that the tender price will not include any such amount.

We have filled the complete information correctly in **Form 14**: Bid Details

**Authorized signatory Name:**

**Date:**

**Name of the Bidder with seal**

**Form 2: Firm Details**

<b>1.</b>	<p><b>Title and name of the Project:</b> Supply of Pantograph Carbon Strips for Rolling Stock Department</p>
<b>2.</b>	<p>State the structure of the Bidder's organization (Bidders to complete/delete as appropriate) Sole Bidder</p>
<b>3.</b>	<p>For Bidders who are individual companies or firms, state the following:</p> <p>Name of Company or firm: ..... c.)</p> <p>Legal status: (e.g. incorporated private company, proprietorship, et .....</p> <p>Registered address: .....</p> <p>Year of incorporation.....</p> <p>Principal place of business: .....</p> <p>Contact person: .....</p> <p>Contact person's title: ..... ID of contact person:</p> <p>Address, telephone, facsimile number and mail</p> <p>.....</p> <p>.....</p> <p>.....</p>

**Form 3: Work Experience**

The following format shall be used for statement of experience of Bidder:

S.No.	Similar Contract description	Contract Identification Number	Award date & Completion date	Employer's Name, address, telephone number, mail etc	Role in contract		If in JV/consortium then % participation	Completion cost	Value of similar work in completed work
					Individual	JV/ Consortium			
1									
2									
3									
4									
Add required number of rows									

**Authorized signatory Name:**

**Date:**

**Name of the Bidder with seal**

**NOTE:**

1. Only the value of contract as executed by the applicant/member in his own name should be indicated. Where a work is undertaken by a group, only that portion of the contract which is undertaken by the concerned applicant/member should be indicated and the remaining done by the other members of the group be excluded. This is to be substantiated with documentary evidence (Experience Certificate/Work Completion Certificate on Client's Letter Head will only be considered) which clearly mentioned the amount for the "Supply of Pantograph Carbon Strips for Rolling Stock Department".
2. The bidder shall upload details of work executed by them in the prescribed format for the works to be considered for qualification of work experience criteria. Documentary proof such as completion certificates from the client clearly indicating the nature/scope of work, actual completion cost and actual date of completion for such work should be uploaded. In case work is executed for private client documentary proof such as copy of work order, Bill of quantities, Bill wise details of payment received certified by CA, TDS certificates for all the payments received, copy of final/ last bill paid by the client should be uploaded. The offers submitted without this documentary proof will not be evaluated.
3. Value of successfully completed portion of any ongoing work up to the last day of the previous month of tender submission will also be considered for qualification of work experience criteria.
4. For completed works, value of work done shall be updated to the last day of the previous month of tender submission price level assuming 5% inflation for Indian Rupees every year and 2% for foreign currency portions per year. The exchange rate of foreign currency shall be applicable 28 days before the submission date of tender.
5. If the qualifying work(s) were done by them in JV/Consortium having different constituents, then the value of work as per their percentage participation in such JV/Consortium shall be considered. This is to be substantiated with documentary evidence.
6. If the above work(s) comprise(s) other works also, then client's certificate clearly indicating the amount of work done in respect of the "similar work" shall be furnished by the bidder in support of work experience along-with their tender submissions.

**Form 4: Capability Statement**

It is Compulsory for the bidder to fill this statement and the bidder must upload those document that support this statement

Tender Reference No: \_\_\_\_\_

Name of Work: \_\_\_\_\_

Name of Bidder: \_\_\_\_\_

<b><u>S.No.</u></b>	<b><u>ELIGIBILITY CRITERIA</u></b>	<b>(To be filled by the Bidder)</b>
1	Sole proprietorship, registered partnership firm (including LLP), public limited company, private limited company or Consortium of any of the above can submit the Bidder. The firms and the companies should be registered in India.	
2	<p>The Bidder should have a minimum experience of having satisfactorily completed in India during last 7 years period ending last day of month previous to the one in which the bids are invited should be either of the following:</p> <ul style="list-style-type: none"> <li>i. One order of similar nature of value not less than Rs. 26.76 lakh (Rupees Twenty Six Lakh Seventy Six Thousand only) or</li> <li>ii. Two orders of similar nature of value not less than Rs 16.72 lakh (Rupees Sixteen Lakh Seventy Two Thousand Only) each or</li> <li>iii. Three orders of similar nature of value not less than Rs 13.38 lakh (Rupees Thirteen Lakh Thirty Eight Thousand Only) each.</li> </ul>	7 years

Supply of Pantograph Carbon Strips for Rolling Stock Department

<b>S.No.</b>	<b><u>ELIGIBILITY CRITERIA</u></b>	<b>(To be filled by the Bidder)</b>	
<b>3</b>	The Bidder should have minimum Average Annual Turnover of Rs. 33.45 Lakh (Rupees Thirty-Three Lakh Forty-Five Thousand only) only in the last 3 (three) audited Financial Years (FY 2022-23, FY 2023-24, FY 2024-25) preceding the Bid Due Date.	FY 2024-25	
		FY 2023-24	
		FY 2022-23	
		Average Annual Turnover	
<b>5</b>	The Bidder should have Positive Profit before Tax in at least 1 (one) year, out of the last 3 (three) audited Financial Years (FY 2022-23, FY 2023-24, FY 2024-25)	FY 2024-25	
		FY 2023-24	
		FY 2022-23	
		Total	
<b>6</b>	The Bidder should be registered with the Goods and Services Tax Authorities.		
<b>7</b>	The Bidder should not have been blacklisted/ banned/ declared ineligible for corrupt and fraudulent practices by the Government of India/ any State Government/ Government Agency and Supreme court and contracts have been terminated/ foreclosed by any company / department due to non- fulfillment of Contractual obligation in last 5 (five) financial years.		

**Form 5: Financial Capability Details**

This is to certify that the Average Annual Turnover and Profitability of \_\_\_\_\_ M/s \_\_\_\_\_ having registered office at \_\_\_\_\_, as applicable, is as below:

S.No.	Financial year	Name of the Bidder	Turnover from Similar Work
1.	FY 2024-25		
2.	FY 2023-24		
3.	FY 2022-23		
	<b>Average Annual Turnover</b>		

S.No.	Financial Year	Name of Bidder	Profitability
1.	FY 2024-25		
2.	FY 2023-24		
3.	FY 2022-23		

**Certificate of the Chartered Accountants/Statutory Auditors**

Based on Audited Accounts and other relevant documents of \_\_\_\_\_ (Name of Bidder), we M/s \_\_\_\_\_, Chartered Accountants/ Statutory Auditors, certify that the above information pertaining to FY 2022-23, FY 2023-24 and FY 2024-25 is correct.

**Signature and Seal of Chartered Accountants/Statutory Auditors** (with membership no.)

**UDIN-**

**Date-**

**Firm Regd. No.-**

**Undertaking**

I/ We\_\_\_\_\_ (M/s\_) declare that the Annual Accounts for FY 2024-25 have not been audited so far. We are submitting the CA certified provisional accounts, which shall be substantiated by the Audited Accounts, when prepared.

**Authorised Signatory**

**(Name & Designation of Authorised Signatory)**

In case the Financial Statements for the latest financial year are not audited and therefore the Bidder cannot make it available, the Bidder shall give an undertaking to this effect and the statutory auditor/charted accountant shall certify the same. In such a case, the Bidder shall provide the Audited Financial Statements for 2 (two) years preceding the year for which the Audited Financial Statement is not being provided. Also, pertaining to latest financial year, the bidder shall submit an affidavit certifying that "The Annual Accounts have not been audited so far. We are submitting the CA certified provisional accounts, which shall be substantiated by the Audited Accounts, when prepared."

**NOTE:**

1. All such documents reflect the financial data of the bidder and not that of sister or parent company.
2. The financial data in above prescribed format shall be certified by CA/ Company Auditor under his signature and stamp in original along with membership no. and UDIN.
3. The Bidder shall provide the audited annual financial statements as required.

**Form 6: Memorandum**

**Name of Work: Supply of Pantograph Carbon Strips for Rolling Stock Department**

I/We agree to keep the quoted rate open for acceptance for 180 days from the due date of submission thereof and not make any modification in its terms and conditions.

I hereby declare that I shall treat the quotation documents, drawings and other records connected with the works as secret/ confidential documents and shall not communicate information derived there from to any person other than the information in any manner prejudicial to the safety of NMRC.

\_\_\_\_\_  
Signature of the bidder with seal Dated:

Witness:

Address:

Occupation

**Form 7: Undertaking**

**Name of Work: Supply of Pantograph Carbon Strips for Rolling Stock Department**

I confirm that we (Bidder), \_\_\_\_\_

- a. Have not been banned in NMRC and any other Metro Organization (100% owned by Govt.)/ Ministry of Housing & Urban affairs/ Order of Ministry of Commerce, applicable for all Ministries must not have banned business with the tenderer (including any member in case of JV/consortium) as on date of tender submission.
- b. Do not have any pending litigation & non-performing contracts during last 5 (five) years. Further, has not been barred by any other Metro Organization (100% owned by Govt.)/ Ministry of Housing & Urban affairs/ Order of Ministry of Commerce, applicable for all Ministries as on date of tender submission.
- c. Have not abandoned any work in last 5 (five) years.
- d. Have not delayed in similar work completion during orders executed in last 5 (five) years.
- e. Do not ever been terminated due to poor performance.
- f. Have not suffered Bankruptcy/ insolvency in last 5 (five) years.
- g. Have not been blacklisted /debarred by any organization.
- h. Neither penalized with liquidated damages of 10% (or more) of the contract value due to delay nor imposed with penalty of 10% (or more) of the contract value due to any other reason in any contract more than 10% of NIT cost of work, during 5 (five) years.
- i. Have not been put on defaulter's list of EPF/ESI/GST/Labor Department etc. as on date of tender submission.
- j. Have not been be involved in any illegal activity and/or has not been charge sheeted for any criminal act during the last 5 (five) years.
- k. Have not submitted any misleading information in the Bid.
- l. Are financially sound to perform the work.

**Authorized signatory Name:**

**Date:**

**Name of the Bidder with seal**

**Form 8: Power Of Attorney**

**(To be on non-judicial stamp paper of appropriate value as per Stamp Act relevant to place of execution.)**

**Power of Attorney to be provided by the Bidding Company in favour of its representative as evidence of authorized signatory's authority.**

Know all men by these presents, We .....(name and address of the registered office of the Bidding Company) do hereby constitute, appoint and authorize Mr./Ms.....(name and residential address) who is presently employed with us and holding the position of , as our Attorney to do in our name and our behalf all or any of the acts, deeds or things necessary or incidental to submission of our Bid for " Supply of Pantograph Carbon Strips for Rolling Stock Department"

"in response to the RFP Document dated\_ issued by Noida Metro Rail Corporation ("NMRC" or "the Corporation"), including signing and submission of the Bid and all other documents related to the Bid, including but not limited to undertakings, letters, certificates, acceptances, clarifications, guarantees or any other document which the employer may require us to submit. The aforesaid Attorney is further authorized for making representations to the NMRC or any other authority, and providing information / responses to the NMRC, representing us in all matters before the NMRC, and generally dealing with the employer in all matters in connection with our Bid till the completion of the bidding process as per the terms of the RFP Document and further till the Contract is entered into with the NMRC and thereafter till the expiry of the Contract.

We hereby agree to ratify all acts, deeds and things done by our said attorney pursuant to this Power of Attorney and that all acts, deeds and things done by our aforesaid attorney shall be binding on us and shall always be deemed to have been done by us.

All the terms used herein but not defined shall have the meaning ascribed to such terms under the RFP Document.

Signed by the within named

..... [Insert the name of the executant's company] through the hand of Mr. .... duly authorized by the Board to issue such Power of Attorney Dated this ..... day of .....Accepted

..... Signature of Attorney  
(Name, designation and address of the Attorney) Attested

..... (Signature of the executants)  
(Name, designation and address of the executants)

Signature and stamp of Notary of the place of execution  
Common seal of ..... has been affixed in my/our presence pursuant to Board of Director's Resolution dated.....

**WITNESS**

**1.**  
.....  
..... (Signature)  
Name .....  
Designation.....

2.

.....

..... (Signature)

Name .....

Designation.....

**Notes:**

1. The mode of execution of the power of attorney should be in accordance with the procedure, if any, laid down by the applicable law and the charter documents of the executants (s) and the same should be under common seal of the executants affixed in accordance with the applicable procedure. Further, the person whose signatures are to be provided on the power of attorney shall be duly authorized by the executants (s) in this regard.
  
2. In the event, power of attorney has been executed outside India, the same needs to be duly notarized by a notary public of the jurisdiction where it is executed.
  
3. Also, wherever required, the executants (s) should submit for verification the extract of the charter documents and documents such as a board resolution / power of attorney, in favour of the person executing this power of attorney for delegation of power hereunder on behalf of the executants (s).

**Form 9: Saleable Form for Tender Document**

Bid No. ....

The required fee of tender form has been deposited in \_\_\_\_\_ Bank A/c No. \_\_\_\_\_ RTGS/NEFT and the scanned copy of UTR receipt with Transaction Id is being enclosed with tender documents. If the copy of UTR receipt is not uploaded with the tender the tender shall be rejected.

DETAILS OF EARNEST MONEY ATTACHED

The required amount of Earnest money has been deposited in \_\_\_\_\_ Bank A/c No. \_\_\_\_\_ RTGS/NEFT and the scanned copy of UTR receipt with transaction Id is being enclosed with tender documents. If the copy of UTR receipt is not uploaded with the tender the tender shall be rejected.

BIDDER



Date:      Signature with Stamp/Seal      Form11: Performa for Clarifications / Amendments on the RFP

Sl. No.	Document	Clause No. and Existing Provision	Clarification required	Suggested Text for the Amendment	Rationale for the Clarification or Amendment

**Authorized signatory**

**Name:**

**Date:**

**Name of the Bidder with seal**

**Form 12: Bid Offer/ BOQ (Format)**

To

Dy.COS  
Noida Metro Rail Corporation (NMRC) Limited  
Block-III, 3rd Floor, Ganga Shopping Complex, Sector-29,  
Noida -201301  
District Gautam Budh Nagar, Uttar Pradesh

***THIS FORM IS NOT TO BE FILLED. THE BIDDERS ARE REQUIRED TO FILL THE FINANCIAL PROPOSAL IN XLS FORMAT AFTER DOWNLOADING THE FORM FROM THE PROCUREMENT WEBSITE FOR THIS TENDER DOCUMENT***

**Sub: Supply of Pantograph Carbon Strips for Rolling Stock Department**

Dear Sir,

I/we have read and examined the RFP document, general terms and conditions for the work.

I/we hereby quote the following Total price for services in rupees for providing Supply of Pantograph Carbon Strips for Rolling Stock Department payable by NMRC.

**Price Schedule for Supply of Pantograph Carbon Strips for Rolling Stock Department**

NUMBER #	TEXT #	NUMBER #	TEXT #	NUMBER #	NUMBER #	NUMBER #	NUMBER #
Sl. No.	Item Description	Quantity	Units	Unit rate (Exclusive GST) In Figures To be entered by the Bidder Rs. P	GST%	Unit rate (Inclusive GST) In Figures Rs. P	TOTAL Cost (Including GST) In Figures Rs. P
		a	b	c	d	e = d + c	f = e * a
1	Pantograph Carbon Strip	150	Nos.				
<b>Total in Figures</b>							
<b>Quoted Rates in Words</b>							

Note:

- The bidder shall mention Quoted Rate (Per item) In Figures.**
- The Amount Arrived at from Quoted Rate, Per item along with Miscellaneous Charges in the Commercial Bid, would be treated as complete in all respect. It will be deemed to include all incidental charges, supervision, transport, contractor's profit and establishment/overheads, all risks & insurance liabilities, compliance of labour laws and other obligations set out or implied in the contract.
- The total payment due to contractor shall be inclusive of all taxes, Tender Requirements, Statutory Contributions, etc.**
- The GST will be reimbursed based on the invoice of GST paid to the concerned authority by the contractor.
- The rates and prices tendered in the priced bill of quantities are for complete work and complete in all respects. It will be deemed to include all plant, labour, supervision, materials, including all leads, lifts, ascents, descants, crossing of Rly. tracks and any other obstructions etc. unloading, loading, handling, re-handling, taxes (including GST), royalty and compensation etc. all temporary works, erection, maintenance, contractor's profit and establishment/ over heads, together with all general risks, insurance liabilities and obligations set out or implied in the contract.
- We have completely read and understood the Bid Document. The Financial Tender submitted is unconditional and fulfills all the requirements of the Tender Document.
- Our Financial Proposal shall be binding upon us subject to the modifications resulting from contract negotiations, up to expiration of the validity period of the Proposal. We understand you are not bound to accept any Proposal you receive.

\_\_\_\_\_  
Signature and Name of the Authorized Person

\_\_\_\_\_  
NAME OF THE BIDDER AND SEAL

**Form 13: Performa of performance security/Bank Guarantee by Bank**

**FORM OF PERFORMANCE SECURITY (GUARANTEE) BY BANK**

1. This deed of Guarantee made this..... day of ..... (month & year) between Bank of..... (Hereinafter called the "Bank") of the one part, and Noida Metro Rail Corporation Limited (hereinafter called "the Employer") of the other part.
2. Whereas Noida Metro Rail Corporation limited has awarded the contract for ..... (name of Work) (hereinafter called "the contract") to M/s.....(Name of the Contractor)....hereinafter called "the Contractor".
3. AND WHEREAS the Contractor is bound by the said Contract to submit to the Employer a Performance Security for a total amount of ₹ ..... (Amount in figures and words).
4. Now we the Undersigned..... (Name of the Bank) being fully authorized to sign and to incur obligations for and on behalf of and in the name of ...(Full name of Bank), hereby declare that the said Bank will Guarantee the Employer the full amount of ₹ ..... (Amount in Figures and Words) as stated above.
5. After the Contractor has signed the aforementioned Contract with the Employer, the Bank is engaged to pay the Employer, any amount up to and inclusive of the aforementioned full amount upon written order from the Employer to indemnify the Employer for any liability of damage resulting from any defects or shortcomings of the Contractor or the debts he may have incurred to any parties involved in the Works under the Contract mentioned above, whether these defects or shortcomings or debts are actual or estimated or expected. The Bank will deliver the money required by the Employer immediately/same day on demand without delay without reference to the Contractor and without the necessity of a previous notice or of judicial or administrative procedures and without it being necessary to prove to the Bank the liability or damages resulting from any defects or shortcomings or debts of the Contractor. The Bank shall pay to the Employer any money so demanded notwithstanding any dispute/disputes raised by the Contractor in any suit or proceedings pending before any Court, Tribunal or Arbitrator/s/ Arbitral Tribunal relating thereto and the liability under this guarantee shall be absolute and unequivocal.
6. This Guarantee is valid till .....(The initial period for which this Guarantee will be valid must be for at least 6-months (six months) longer than the anticipated expiry date of contract period as stated in Clause 4.2 of the "General Conditions of Contract").
7. At any time during the period in which this Guarantee is still valid, if the Employer agrees to grant a time extension to the Contractor or if the Contractor fails to complete the Works within the time of completion as stated in the Contract, or fails to discharge himself of the liability or damages or debts as stated under Para 5, above, it is understood that the Bank will extend this Guarantee under the same conditions for the required time on demand by the Employer and at the cost of the Contractor.
8. The Bank agrees that no changes, addition, modifications to the terms of the contract Agreement or to any documents, which have been or may be made between the Employer and the Contractor, will

Supply of Pantograph Carbon Strips for Rolling Stock Department

in no way release us from the liability under this Guarantee; and the Bank, hereby, waives any requirement for notice of any such change, addition or modification to the Bank.

- 9. The Guarantee hereinbefore contained shall not be affected by any change in the Constitution of the Bank or of the Contractor.
- 10. The neglect or forbearance of the Employer in enforcement of payment of any moneys, the payment whereof is intended to be hereby secured or the giving of time by the Employer for the payment hereof shall in no way relieve the bank of their liability under this deed.
- 11. The expressions "the Employer", "the Bank" and "the Contractor" hereinbefore used shall include their respective successors and assigns.
- 12. Notwithstanding anything contained herein:
  - (a) Our liability under this Bank Guarantee shall not exceed Rs.....(Rs )
  - (b) This Bank Guarantee shall be valid up to .....
  - (c) We are liable to pay the Guarantee amount or part thereof under this Bank Guarantee only & only if you serve upon us a written claim or demand on or before.....

In witness whereof I/We of the bank have signed and sealed this guarantee on the.....day of (Month & Year) being herewith duly authorized.

**For and on behalf of the \_\_\_\_\_ Bank.**

**Signature of authorized Bank official**

Name: .....

Designation: .....

I.D. No. : .....

Stamp/Seal of the Bank: .....

Signed, sealed and delivered for and on behalf of the Bank by the above named\_ In the presence of:

Witness 1.

Witness 2.

Signature .....

Signature .....

Name .....

Name .....

Address .....

Address .....

Notes:

- The stamp papers of appropriate value shall be purchased in the name of the Bank, who issues the 'Bank Guarantee'.
- The 'Bank Guarantee' shall be from the Scheduled Commercial Bank based in India, acceptable to Employer.

**Form 14: Bid Details**

**The following list is intended to help the bidders in submitting offer which are complete. An incomplete offer is liable to be rejected. Bidders are advised to go through the list carefully and take necessary action.**

Supply of Pantograph Carbon Strips for Rolling Stock Department

S.No.	Particulars	Attached Yes / No / Not Applicable	Page no. (Mandatory)
1	Bid Processing Fees		
2	Earnest Money Deposit		
3	<b>Form 1:</b> Letter of Proposal Submission		
4	<b>Form 2:</b> Firm Details		
5	<b>Form 3:</b> Work Experience		
6	<b>Form 4:</b> Capability Statement		
7	<b>Form 5:</b> Financial Capability Details		
8	<b>Form 6:</b> Memorandum		
9	<b>Form 7:</b> Undertaking		
10	<b>Form 8:</b> Power Of Attorney		
11	<b>Form 9:</b> Saleable form for Tender Document		
12	<b>Form 10:</b> Declaration of Refund of Earnest Money		
13	<b>Form 11:</b> Performa for Clarifications / Amendments on the RFP		
14	<b>Form 12:</b> Bid offer/BOQ Format		
15	<b>Form 13:</b> Performa of performance security/Bank Guarantee by Bank		
16	<b>Form 14:</b> Bid Details		
17	Registration certificate of the firm/ Partnership deed/ certificate of incorporation, affidavit in case of sole proprietorship etc.		
18	Self-attested copy of PAN, ITR for FY 2022-23, FY 2023-24 and FY 2024-25.		
19	Copy of RFP and Corrigendum/Addendum if any signed by Authorized Signatory on each page		
20	Any other document asked by the Purchaser if submitted, specify the documents Or Any other document which the Bidder considers relevant		

**Annexure-A**

**CARBON STRIP DRAWING**

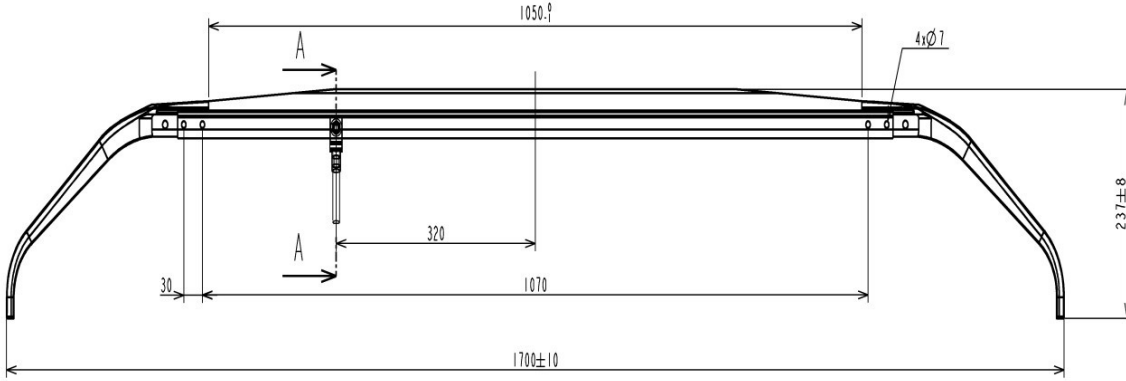

**Pic: -1**

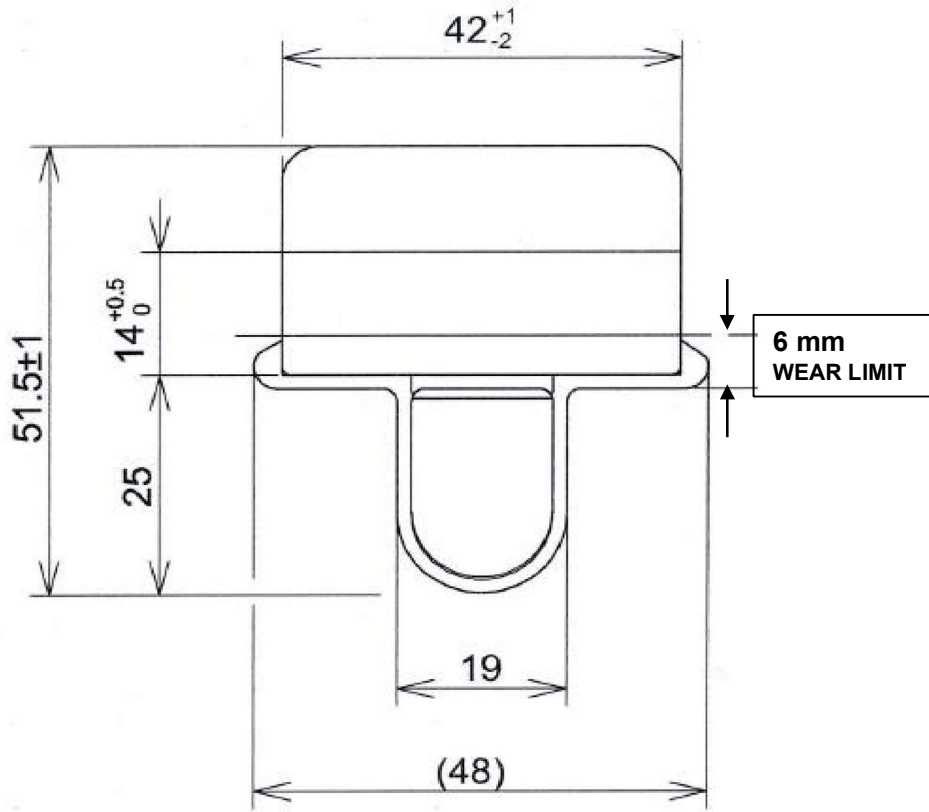

**Pic: -2**